

MODULO A3 "SALINA"

SCOMPOSIZIONE APPARTAMENTI

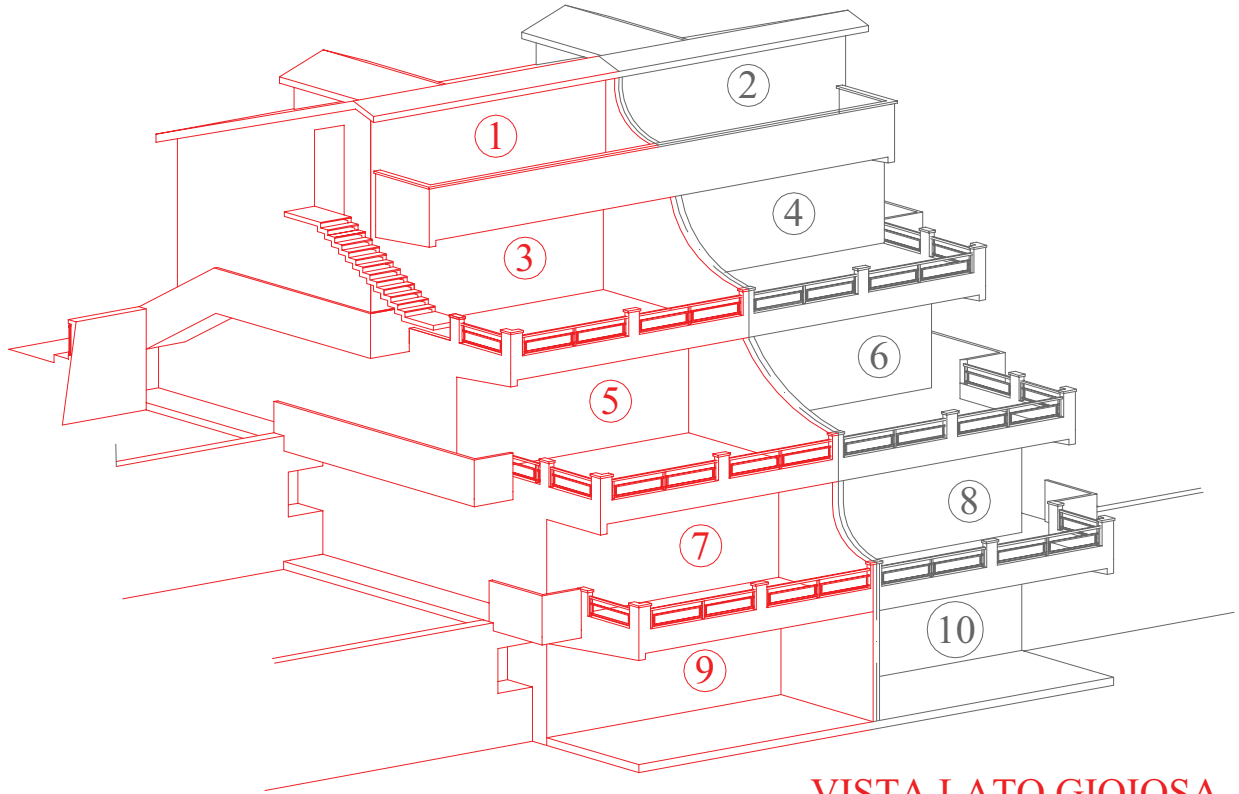

VISTA LATO GIOIOSA

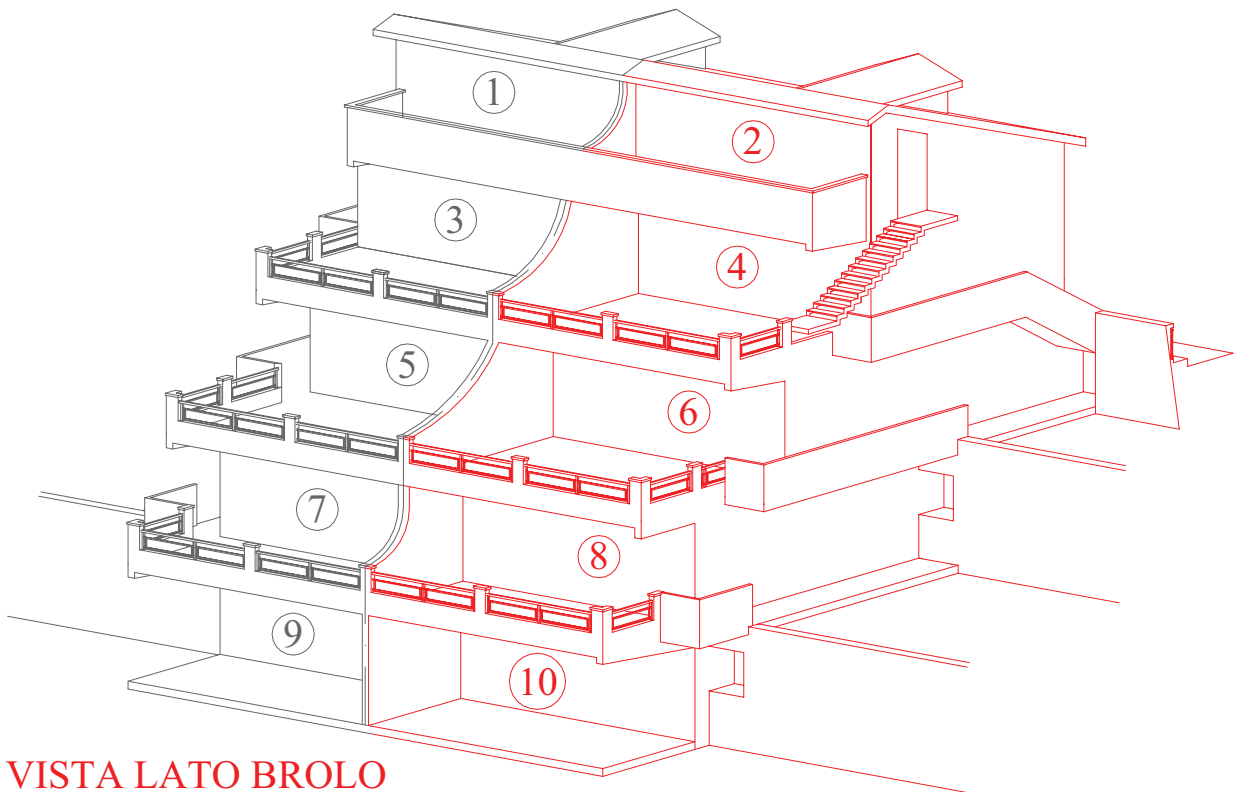

VISTA LATO BROLO

MODULO A3 "SALINA"

SOTTOTETTO n° 1 - (Lato Gioiosa)

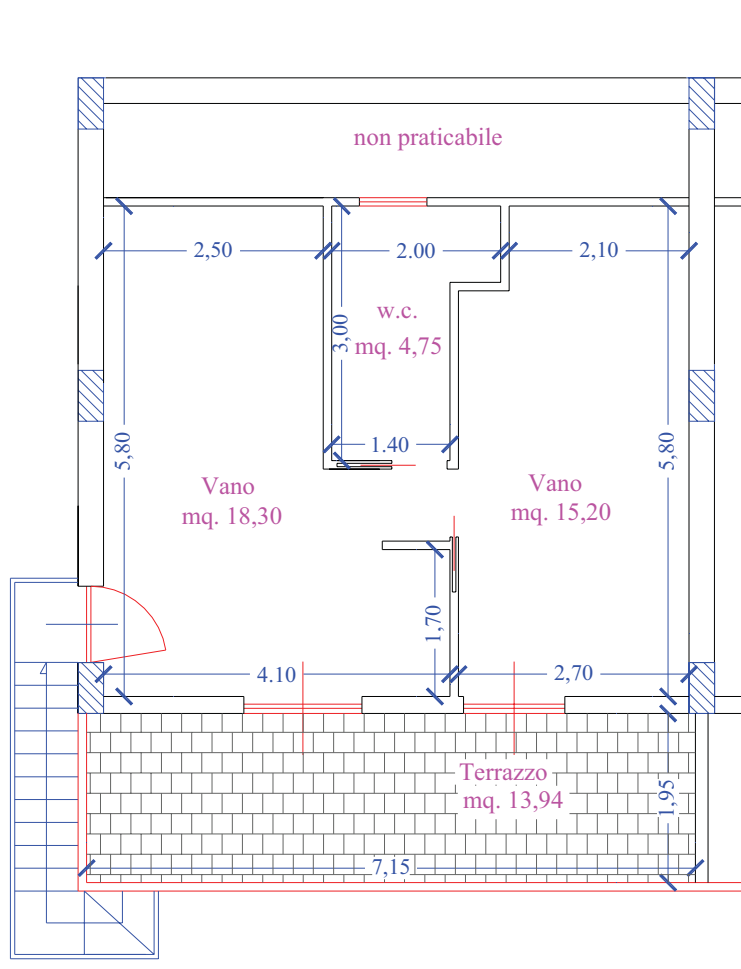

DATI TECNICI

- superficie lorda	=	mq. 44,00
- terrazzi lordi	=	mq. 15,40
- posto auto	=	mq. 14,00

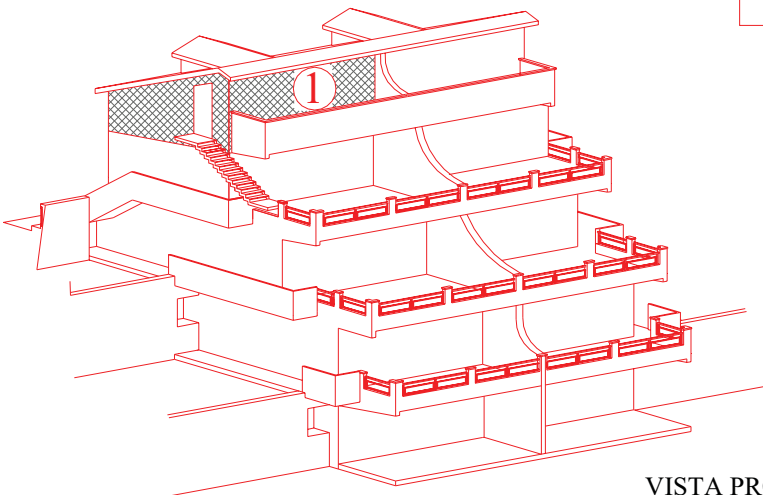

VISTA PROSPETTICA MODULO A3 - "SALINA"



MODULO A3 "SALINA"

SOTTOTETTO n° 2 - (Lato Brolo)

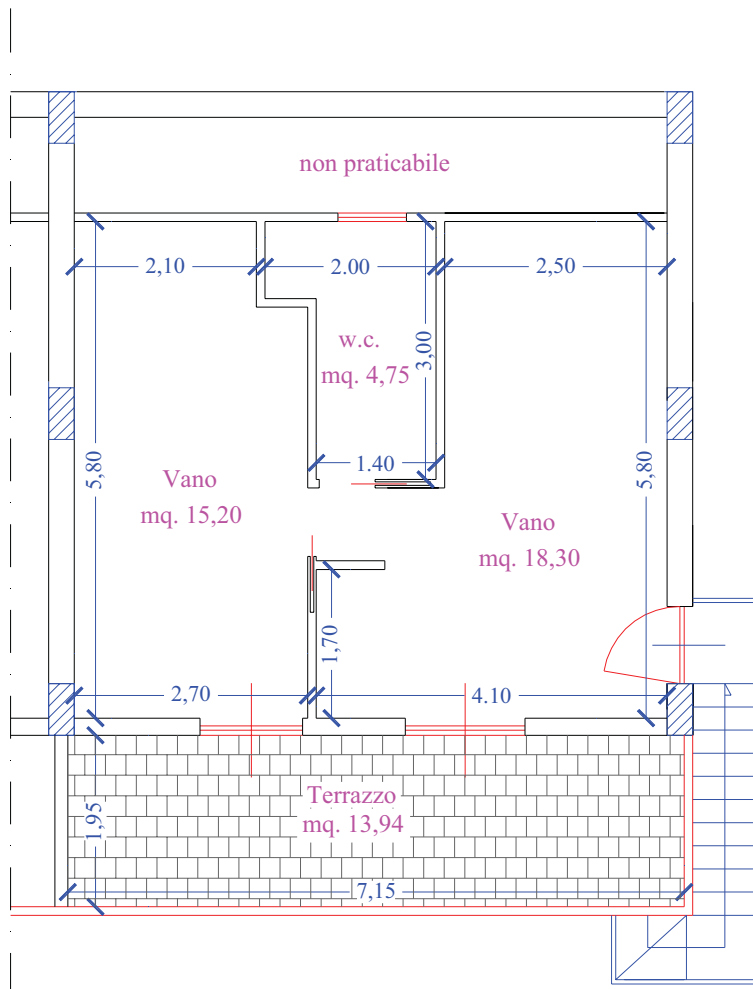

DATI TECNICI

- superficie lorda	=	mq. 44,00
- terrazzi lordi	=	mq. 15,40
- posto auto	=	mq. 14,00

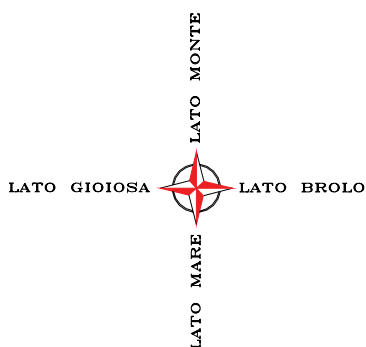
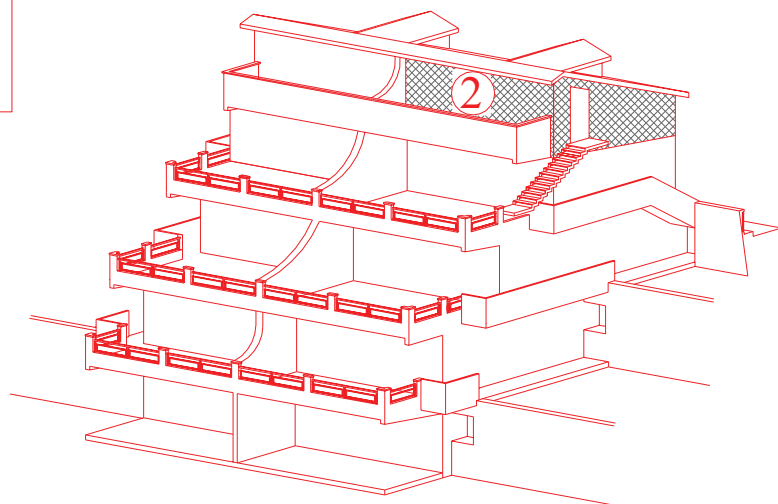

VISTA PROSPETTICA MODULO A3 - "SALINA"

MODULO A3 "SALINA"

APPARTAMENTO n° 3 - (Lato Gioiosa)

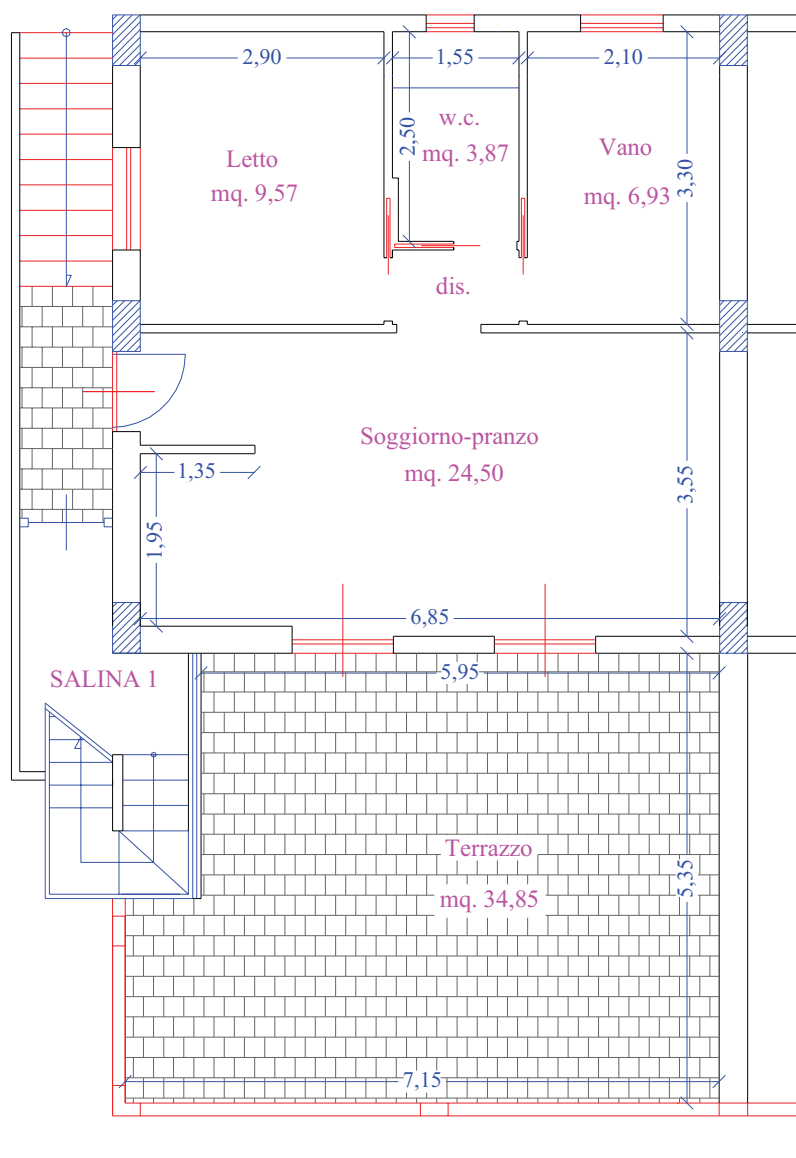

DATI TECNICI

- superficie lorda	=	mq. 55,60
- terrazzi lordi	=	mq. 37,00
- posto auto	=	mq. 14,00

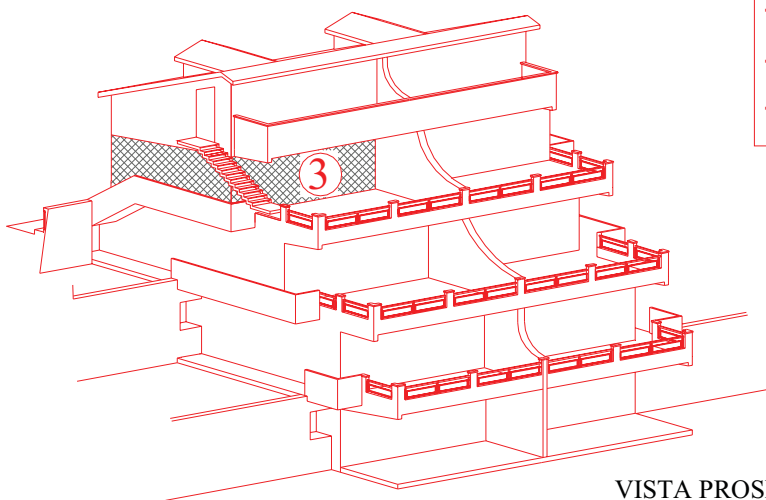

VISTA PROSPETTICA MODULO A3 - "SALINA"



MODULO A3 "SALINA"

APPARTAMENTO n° 4 - (Lato Brolo)

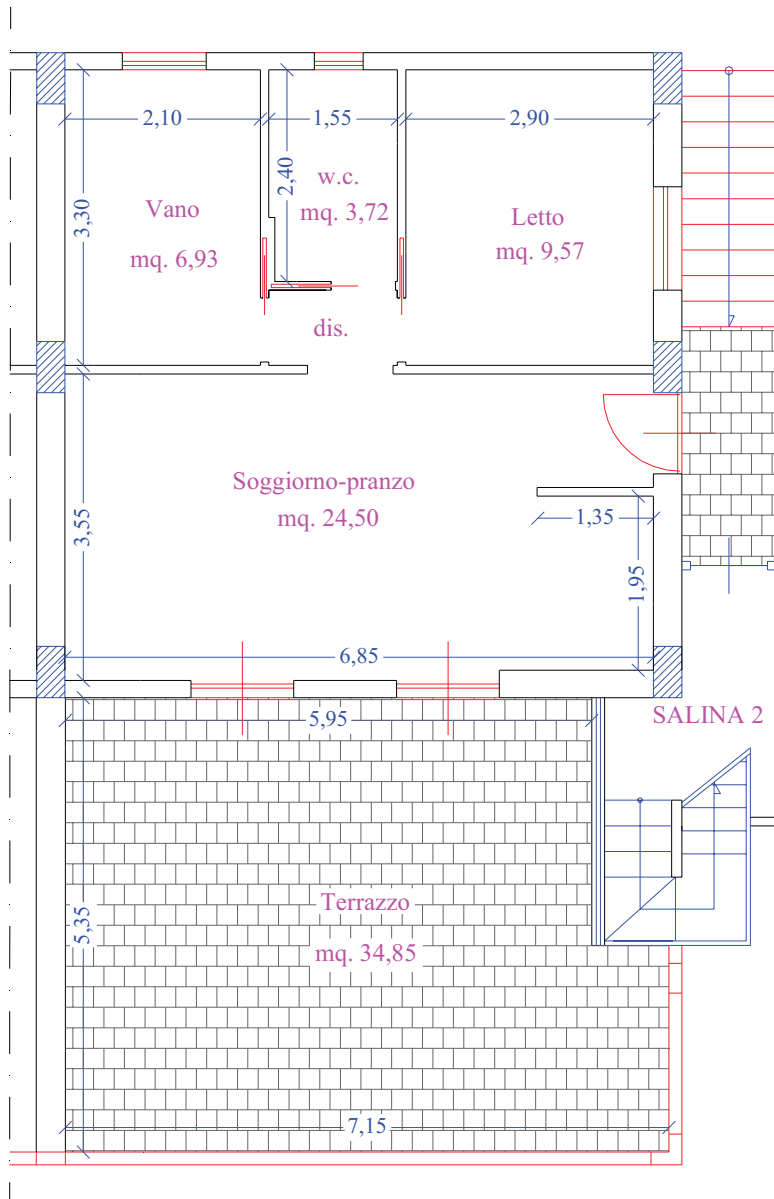

DATI TECNICI

- superficie lorda = mq. 55,60
- terrazzi lordi = mq. 37,00
- posto auto = mq. 14,00

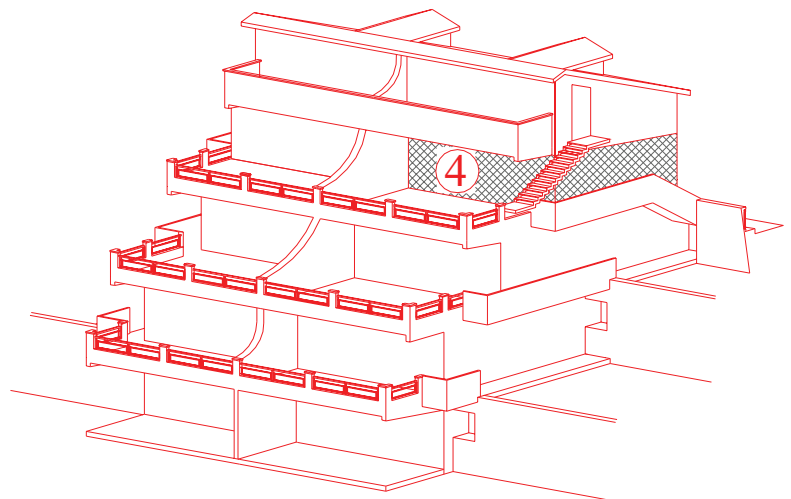
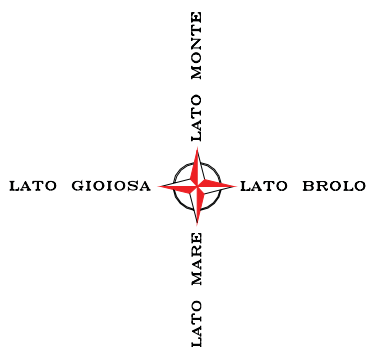

VISTA PROSPETTICA MODULO A3 - "SALINA"

MODULO A3 "SALINA"

APPARTAMENTO n° 5 - (Lato Gioiosa)

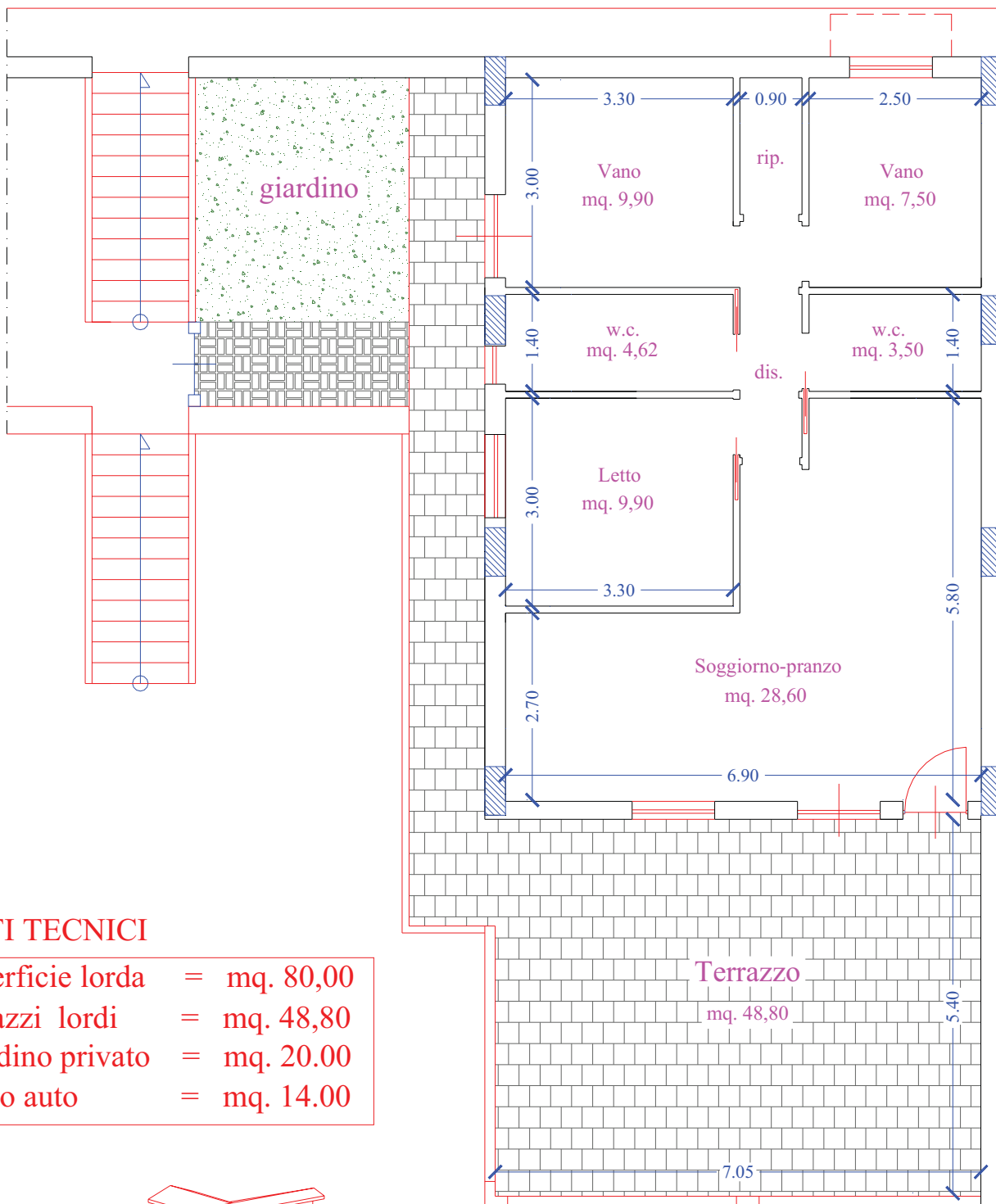

DATI TECNICI

- superficie lorda = mq. 80,00
- terrazzi lordi = mq. 48,80
- giardino privato = mq. 20,00
- posto auto = mq. 14,00

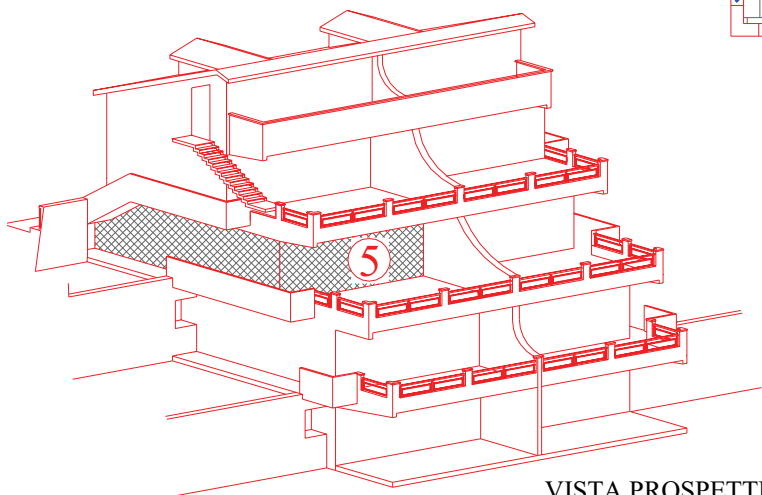

VISTA PROSPETTICA MODULO A3 - "SALINA"

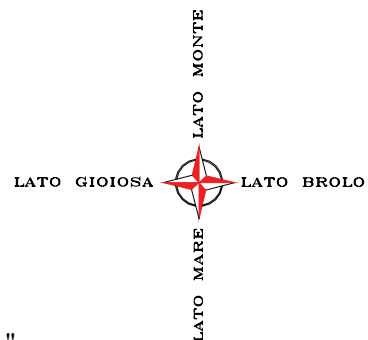

MODULO A3 "SALINA"

APPARTAMENTO n° 6 - (Lato Brolo)

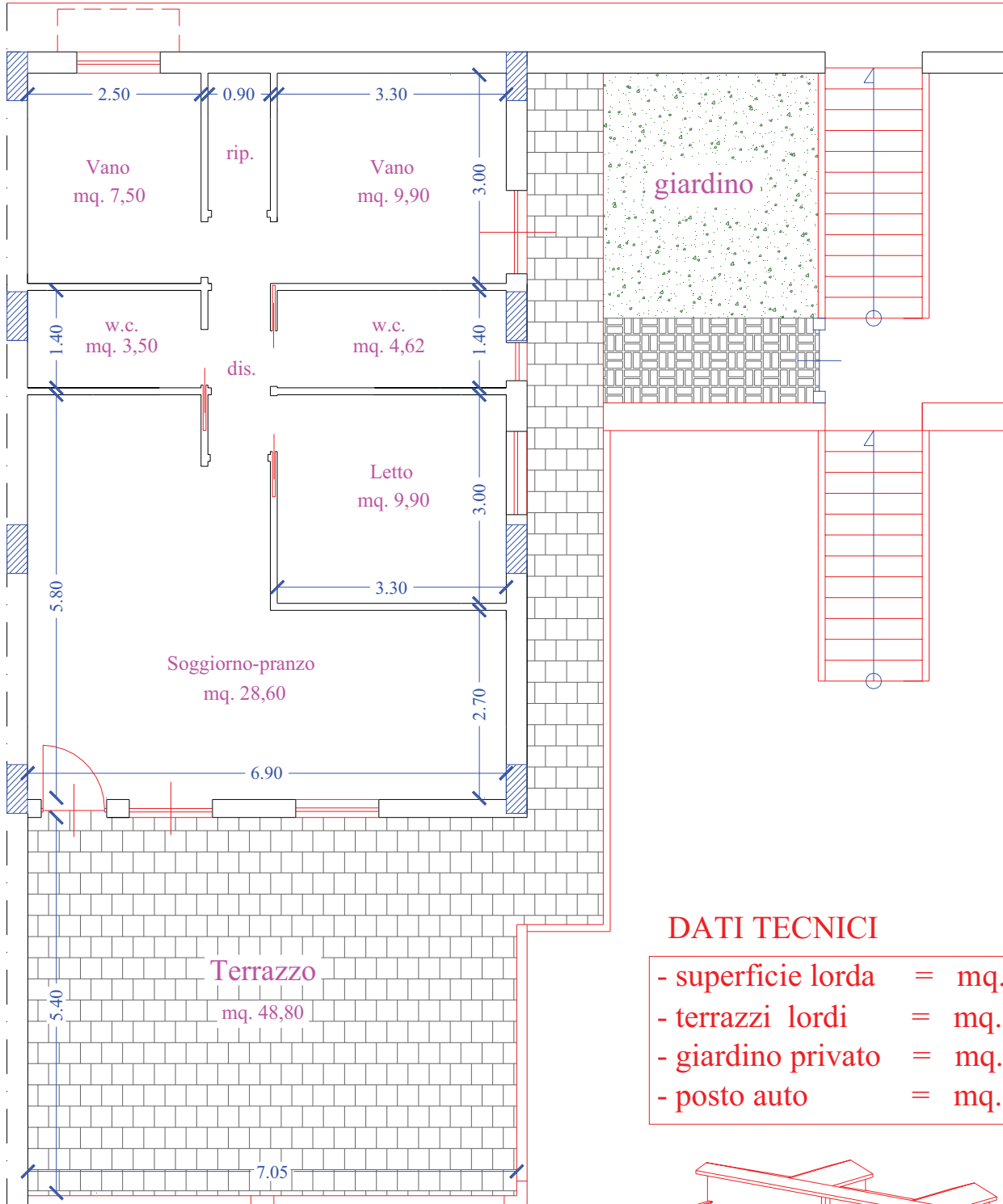

DATI TECNICI

- superficie lorda = mq. 80,00
- terrazzi lordi = mq. 48,80
- giardino privato = mq. 20,00
- posto auto = mq. 14,00

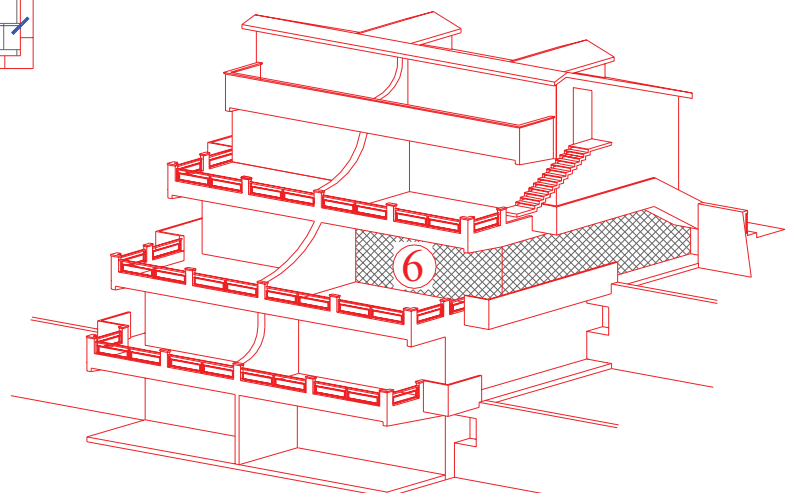

VISTA PROSPETTICA MODULO A3 - "SALINA"

MODULO A3 "SALINA"

APPARTAMENTO n° 7 - (Lato Gioiosa)

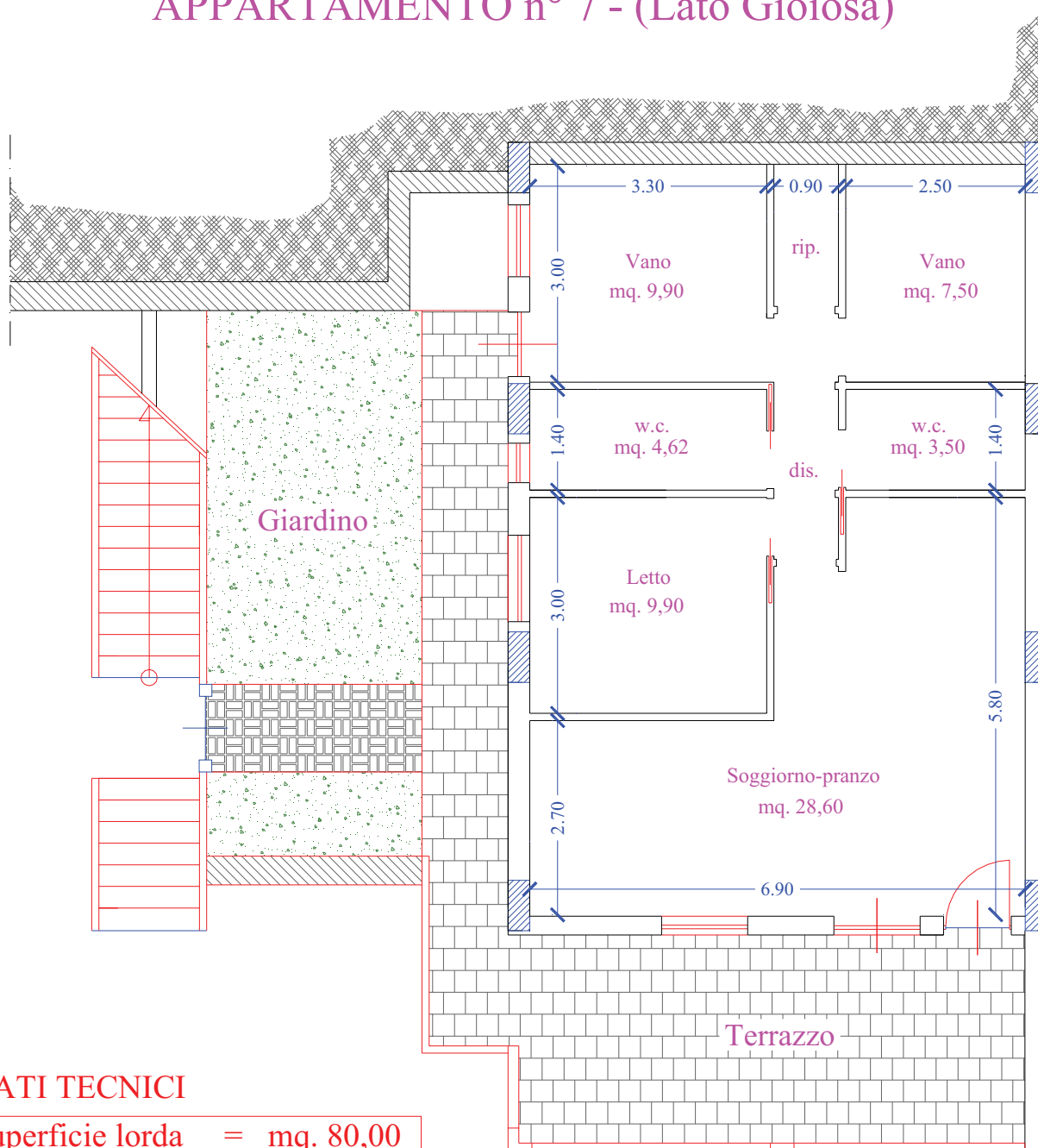

DATI TECNICI

- superficie lorda = mq. 80,00
- terrazzi lordi = mq. 25,00
- giardino privato = mq. 31,80
- posto auto = mq. 14,00

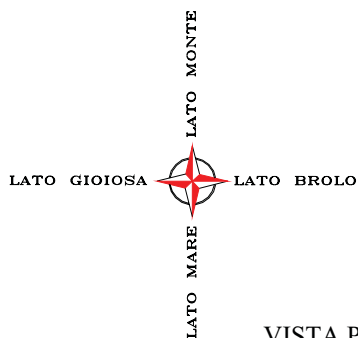

VISTA PROSPETTICA MODULO A3 - "SALINA"

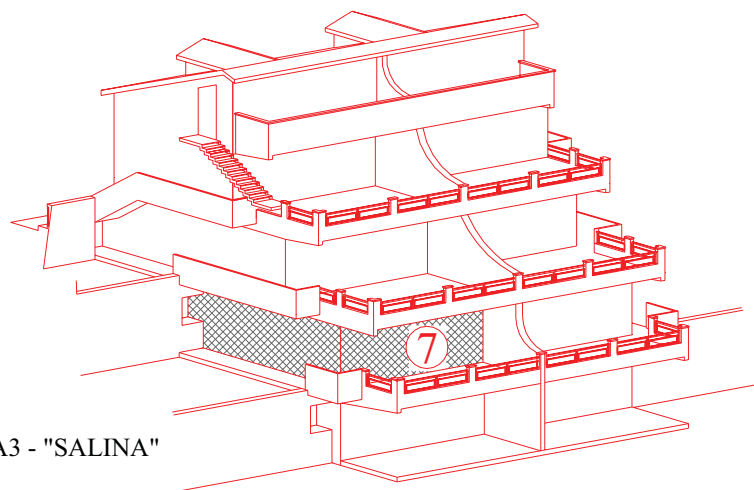

MODULO A3 "SALINA"

APPARTAMENTO n° 8 - (Lato Brolo)

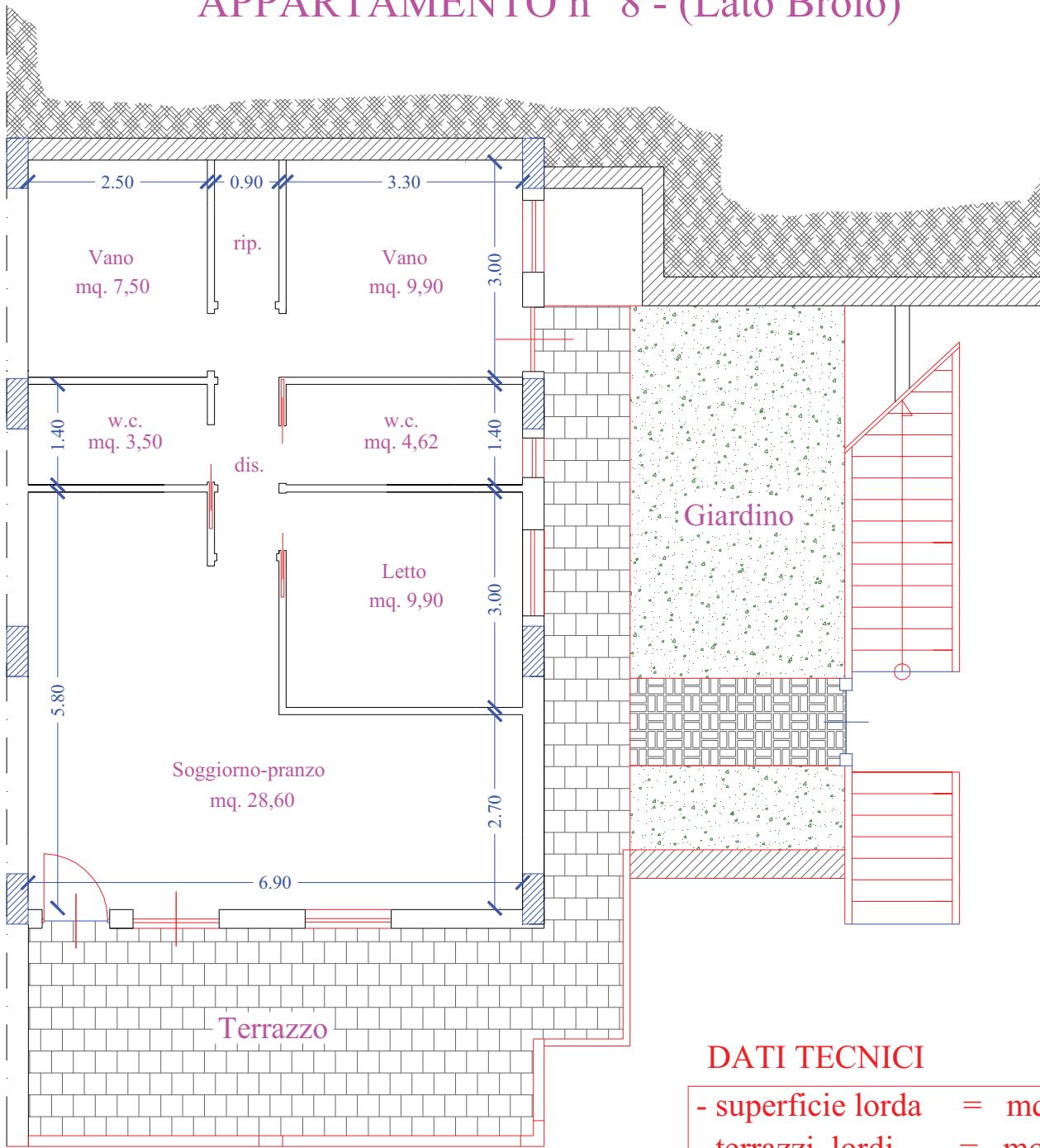

DATI TECNICI

- superficie lorda	=	mq. 80,00
- terrazzi lordi	=	mq. 25,00
- giardino privato	=	mq. 31,80
- posto auto	=	mq. 14,00

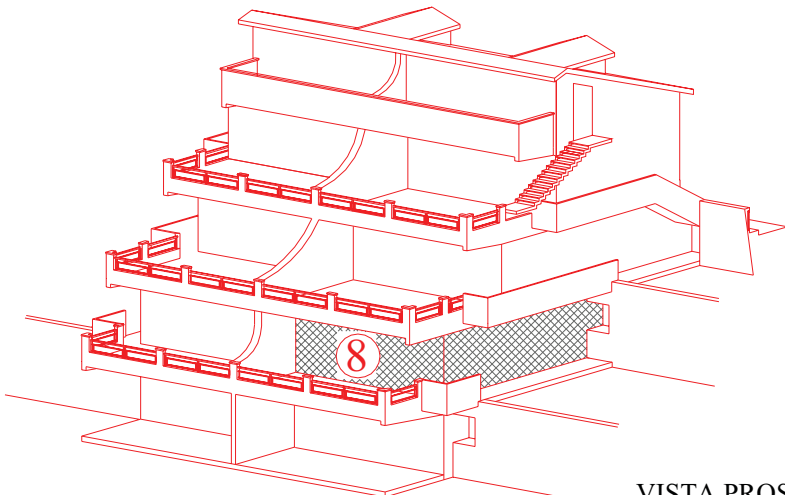

VISTA PROSPETTICA MODULO A3 - "SALINA"

